



The only parts that may require replacing are the rubber dust cover (13) and the rubber washer (12). A new rubber dust cover can be fitted by stretching it over the eye of the brake rod with the large end towards the eye.

Push the brake rod through the cylinder of the expander housing so that the eye projects at the outer end. Attach the expander cone to the rod by means of the pin, and then draw them together into the expander housing so that the ends of the pin engage with the slots in the housing.

Pull the brake rod so that the expander cone is about $\frac{1}{4}$ " from the "off" position, (The expander cone is shown in the "off" position in Fig.17) and then place the roller in the deep end of the inclined slot of the plunger and slide them together into one of the plunger bores, with the retaining pin slot in the plunger in line with the corresponding hole in the housing.

Insert the retaining pin and then open split end to secure. Fit the other plunger, the roller and the retaining pin in a similar manner.

Place the dust cap in position and lightly swage it at three points to secure, using a small blunt chisel taking care not to distort the expander housing.

To refit.

Place in position the assembled expander unit by threading the brake rod (14 Fig.17) and the rubber dust cover (13), through the hole in the brake carrier plate and the water excluder, and attach by means of the plain washers, Thackeray washers and castellated nuts. The nuts must be screwed tight, released one full turn and then secured with a new split pin of the correct size.

Make sure that the expander unit is free to slide to and fro through the limit of travel provided by the elongated holes in the brake carrier plate and there should be only a moderate friction load from the partly compressed Thackeray Washers.

Re-connect the jaw (15) to the equaliser lever by means of the pin (17) and secure the latter by fitting a new split pin of the correct size.

The water excluder should not be fitted until the final assembly operation. (See appropriate paragraph.)

THE REAR BRAKE ADJUSTERS:

Whenever the rear brake shoes are removed for relining, the adjusters should also be removed, dismantled, cleaned and greased.

To remove.

Remove the two setscrews and spring washers (23 and 22 Fig.17) and the plain washer (21) and then withdraw the adjuster from the brake carrier plate.



To dismantle.

Withdraw the plungers (18) from the housing and then remove the adjuster screw (19) by screwing it inwards, having first removed the rubber washer (24) and the plain washer (25). The adjusters are identical.

To re-assemble.

It is essential that all parts should be perfectly clean and laid on a piece of clean paper before re-assembling. The internal parts should be lightly lubricated with hub grease.

Replace the adjuster screw in the housing, screw it back to the fully off position, then correctly replace the plungers. Note that the plungers are handed, as it is possible to assemble them the wrong way round. When assembled the inclined faces 'A' (Fig.18) on the inner ends of the plungers must be parallel when viewed along the axis of the adjuster screw. When the plungers are correctly assembled there are four

- 18. Plunger.
- 19. Adjuster Screw.
- 20. Adjuster Housing.
- 21. Plain Washer.
- 22. Spring Washer.
- 23. Setscrew.
- 24. Rubber Washer.
- 25. Washer.
- 26. Hand Wheel.
- 27. Locknut.

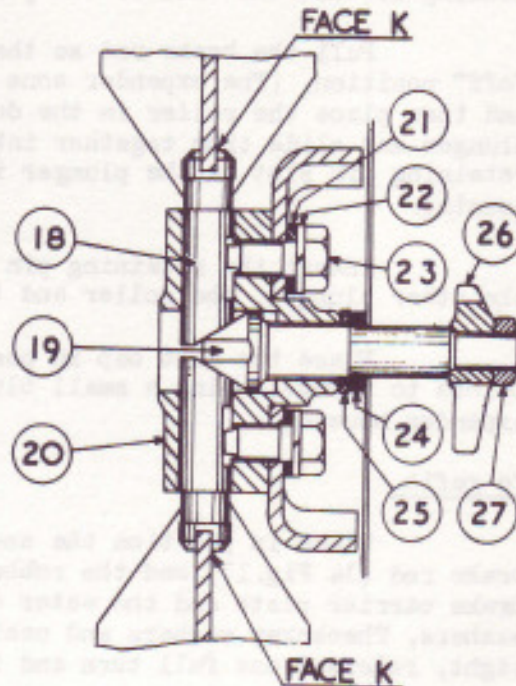

FIG. 17. SECTION THROUGH REAR BRAKE ADJUSTER.

evenly spaced clicks per turn of the adjuster screw.

Should they be incorrectly assembled there will be eight unequally spaced clicks per turn.

Place the plain washer and the rubber washer in position on the adjuster screw, fitting a new rubber washer if necessary.

To re-fit.

Place the adjuster unit in position and secure with the two setscrews and the spring and plain washers.

It will be observed upon reference to Fig.17 that the setscrews also locate the plungers and it is important to note that the ends of the setscrews do not nip against the flats on the plungers. This can be checked by slightly rotating the plungers which will indicate the clearance.



The water excluder should not be fitted until the final assembly operation. (See appropriate paragraph)

TO FIT A SET OF SHOES COMPLETE WITH NEW LINERS.

NOTE: Keep all grease off linings and do not handle linings any more than necessary. Inspect shoe pull-off springs and replace if stretched or damaged.

- (i) Detach the pull-off springs from the old shoes. Fit the spring (115 and 31) to both shoes. Refer to Figs. 9 and 15, which show the springs correctly fitted.

- (ii) Fit the other pull-off spring (101 and 40) to the trailing shoe and then anchor the other end of the spring to the anchor pillar (99 and 37).

Expand the spring and then place the tip of the trailing shoe into the slot in the plunger of the expander unit. Some effort will be required to do this owing to the load exerted by the pull-off spring.

- (iii) Place the other end of the trailing shoe into the slot in the plunger of the adjuster unit. With a screwdriver resting in a convenient position, squarely lift the leading shoe first into the slot of the plunger of the adjuster unit and then into the slot of the plunger of the expander unit.

- (iv) Replace the inter-shoe linkage onto the fulcrum lever pin. Hold the link (108 and 47) in position on the trailing shoe and replace the pin (109 and 48), the locking plate (110 and 49) and the setscrew and spring washer (111 and 50) to lock.

- (v) Hold the jaw (98 and 38) in position on the leading shoe and replace the pin (95 and 34), but do not fit the locking plate and the setscrew (which retain it), at this stage.

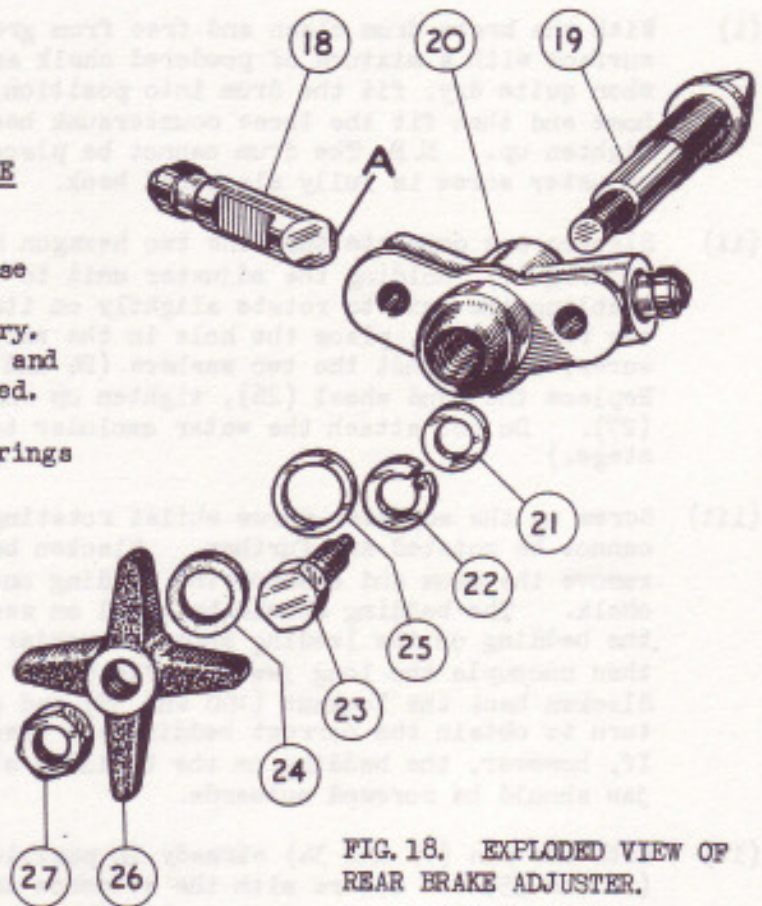

FIG. 18. EXPLODED VIEW OF REAR BRAKE ADJUSTER.

ADJUSTMENT OF THE INTER-SHOE LINKAGE FOR FRONT & REAR BRAKES.

NOTE: Should it not have been found necessary to remove the front hydraulic expanders then it will be necessary before proceeding further, to ensure that they are free to slide to and fro through the limit of travel provided by the elongated holes in the brake carrier plate.



- (i) With the brake drum clean and free from grease, cover the working surface with a mixture of powdered chalk and methylated spirit, and when quite dry, fit the drum into position, ensure that it is fully home and then fit the three countersunk headed retaining screws and tighten up. N.B. The drum cannot be placed in position unless the adjuster screw is fully slackened back.
- (ii) Slacken one complete turn the two hexagon headed screws (78, Fig.13, and 23, Fig.17), holding the adjuster unit to the carrier plate, thus enabling the unit to rotate slightly on its spigot. (In the case of the rear brakes, place the hole in the water excluder over the adjuster screw, noting that the two washers (24 and 25, Fig.17) are in position. Replace the hand wheel (26), tighten up and secure with the locknut (27). Do not attach the water excluder to the carrier plate at this stage.)
- (iii) Screw up the adjuster screw whilst rotating the drum until the drum cannot be rotated any further. Slacken back the adjuster screw, remove the drum and examine the bedding on the shoes as shown by the chalk. The bedding should be equal on each shoe. If, for example, the bedding on the leading shoe is heavier than on the other shoe, then uncouple the long jaw (98, Fig.9 and 38, Fig.15) from the shoe. Slacken back the locknut (100 and 39) and screw up the jaw half a turn to obtain the correct bedding and then re-tighten the locknut. If, however, the bedding on the trailing shoe is heavier, then the jaw should be screwed outwards.
- (iv) With the pin (95 and 34) already in position, refit the locking plate (96 and 35) and secure with the setscrew and spring washer (97 and 36).
- (v) Remove all trace of chalk from the brake shoe linings and drum, refit the brake drum and secure with the three retaining screws.
- (vi) When the bedding of the leading and trailing shoe linings with the drum has been equalised by adjustment of the inter-shoe linkage, then it will be necessary to set the angular position of the adjuster unit. The set-screws which retain the adjuster unit pass through clearance holes in the brake carrier plate, thus allowing the adjuster unit to rotate slightly about its spigot when the setscrews are slackened back. Proceed as follows:-
 - (a) Turn the adjuster screw as far as possible in a clockwise direction so as to "lock" the brake shoes against the drum.
 - (b) Tighten up the two hexagon headed setscrews, which retain the adjuster unit.
 - (c) Slacken back the adjuster screw one notch at a time until the brake drum is free to rotate.

TO CHECK FLOAT OF BRAKE EXPANDER UNITS ON THE CARRIER PLATES OF FRONT AND REAR BRAKES.

In order that the brake shoes may be self-centering, the expander units are attached to the brake carrier plates in such a way that they are free to slide in either direction, i.e. either towards the leading shoe or towards



the trailing shoe. They should be free to slide a minimum of .060" in either direction. A check should be made to ensure that the above minimum clearance is available, to do this proceed as follows:-

- (a) Remove the brake drum and mark the position of the expander unit relative to the carrier plate, by scribing lines at the ends of the expander housing, or by any other convenient method. See Fig.19.
- (b) Insert a screwdriver between one brake shoe web and the end of the expander housing, lever the shoe tip away from the expander unit, and note the free travel of the expander unit obtainable from the normal position. A convenient way is to scribe a second line at the opposite end of the expander housing.
- (c) Repeat (b) inserting the screwdriver between the other shoe web and the expander housing, and note the free travel of the expander unit in the other direction.
- (d) As mentioned above, the float of the expander unit must not be less than .060" in each direction, as indicated by the distance between the two scribed lines, if this method is used.

FINAL ASSEMBLY OPERATIONS OF FRONT AND REAR BRAKES.

- (i) Check that all pins, locking plates, setscrews and spring washers have been correctly refitted to the inter-shoe linkage.
- (ii) Refit the drums and finally secure with the retaining screws.
- (iii) Rear brakes only. Replace the water excluder (33 Fig.15) and secure with the four nuts and spring washers. Roll the rubber washer (ring) into its groove on the expander housing and replace the rubber dust cover.

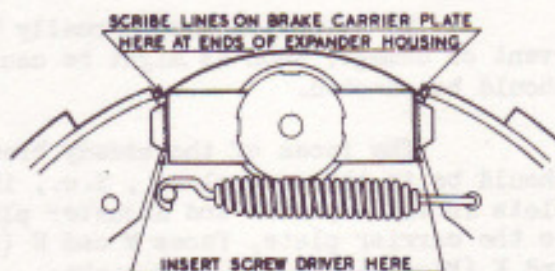

FIG. 19. CHECKING FLOAT OF EXPANDER UNITS.

Connect up the jaw (15) to the equaliser lever, replace the pin (17) and secure with a new split pin of the correct size. (See Fig.4 Sub-Section BJ.1.)

- (iv) Screw up the adjuster screw as far as it will go without having to use undue strength to turn it past the last notch and check for free rotation of the drum.
- (v) Mount the road wheels, refit to each wheel the five securing nuts and tighten up.
- (vi) Lower the car to the ground again by removing the blocks or trestles and finally retighten the wheel securing nuts and refit the discs and hub caps.



When refitting the wheel discs, care must be taken to get the valve centred in the hole provided. As previously explained the hub caps securing the discs have right-hand threads for both "off-side and near-side" wheels. These hub caps are necessary only to retain the disc and should therefore not be overtightened.

The correct tension is attained by giving the nut one complete turn after the disc has been felt to be in light contact with the rubber stops on the wheel centre.

There should be a small gap, approximately .100", between the edge of the disc and the wheel. Overtightening distorts and brings the disc in contact with the wheel, thus causing creaks and rattles.

NOTE: Should the hydraulic expanders have been removed or should any of the hydraulic pipe lines have been disconnected, then it will be necessary to bleed the system as described in sub-section BJ.2.

BRAKE SHOE STEADY BRACKETS.

The front brake shoe steady brackets (113) are shown on Fig.9 and the rear brake shoe steady brackets (32) are shown on Fig.15.

No attention need normally be paid to these brackets, but in the event of damage, such as might be caused by an accident, then their alignment should be checked.

The faces of the steady brackets which contact the brake shoe webs should be in the same plane, i.e., in line with the side faces of the shoe slots in the expander and adjuster plungers on the side of the slots nearer to the carrier plate, faces M and N (Fig.13) for the front brakes and faces J and K (Fig.17) for the rear brakes. While it is permissible, however, for the faces of the steady brackets to be up to .015" below this plane (nearer to the carrier plate), they must never be above it (away from the carrier plate) as this would cause uneven bedding across the width of the shoes.

ADJUSTMENT OF BRAKE RODS AND LINKAGES.

Fig.20 shows the method of adjusting the brake rods and linkages.

It is recommended that these adjustments should be checked when the brakes are re-lined.

Also, if an engine, gearbox or rear axle is removed at any time, or if any of the rods or linkages have to be replaced due to damage, then it will be necessary to check over and adjust all the linkages.

It is important that the adjustments should be carried out in the order specified on Fig.20.

Check that any split pins removed have been replaced by new ones of the correct size.

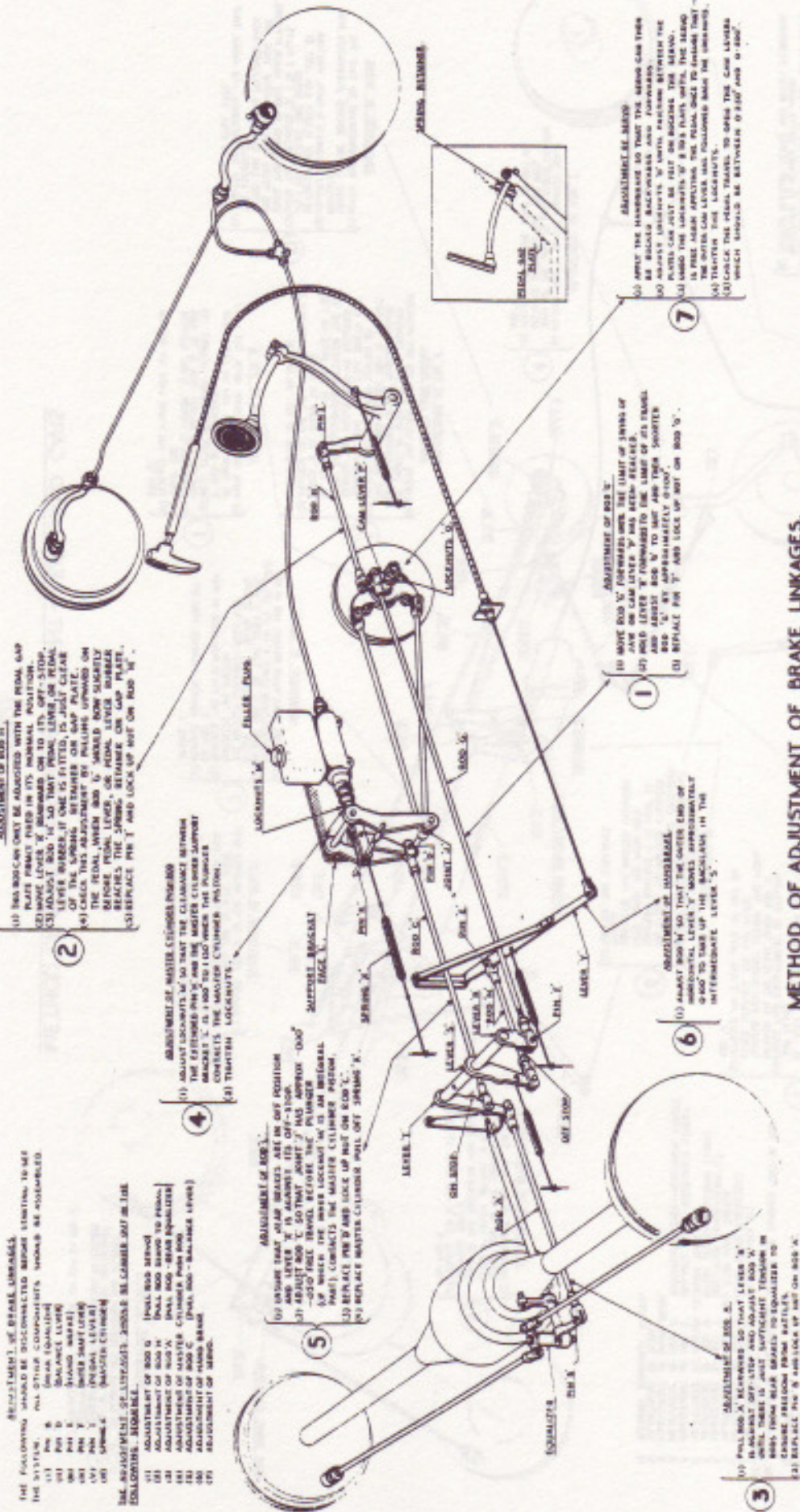

ADJUSTMENT OF BRAKE LINKAGES.
 THE FOLLOWING SHOULD BE DISCONNECTED BEFORE STARTING TO SET THE SYSTEM. ALL OTHER COMPONENTS SHOULD BE ASSEMBLED.

- (1) PIN B
- (2) PIN D
- (3) PIN E
- (4) PIN F
- (5) PIN G
- (6) PIN H
- (7) PIN I
- (8) PIN J
- (9) PIN K
- (10) PIN L
- (11) PIN M
- (12) PIN N
- (13) PIN O
- (14) PIN P
- (15) PIN Q
- (16) PIN R
- (17) PIN S
- (18) PIN T
- (19) PIN U
- (20) PIN V
- (21) PIN W
- (22) PIN X
- (23) PIN Y
- (24) PIN Z

ADJUSTMENT OF ROD G.
 (1) ADJUST ROD G SO THAT THE CLEARANCE BETWEEN THE MASTER LOCKNUT AND THE MASTER CYLINDER PIN IS 1/16" TO 1/8".

ADJUSTMENT OF ROD H.
 (1) ADJUST ROD H SO THAT THE CLEARANCE BETWEEN THE MASTER LOCKNUT AND THE MASTER CYLINDER PIN IS 1/16" TO 1/8".

ADJUSTMENT OF ROD I.
 (1) ADJUST ROD I SO THAT THE CLEARANCE BETWEEN THE MASTER LOCKNUT AND THE MASTER CYLINDER PIN IS 1/16" TO 1/8".

ADJUSTMENT OF ROD J.
 (1) ADJUST ROD J SO THAT THE CLEARANCE BETWEEN THE MASTER LOCKNUT AND THE MASTER CYLINDER PIN IS 1/16" TO 1/8".

ADJUSTMENT OF ROD K.
 (1) ADJUST ROD K SO THAT THE CLEARANCE BETWEEN THE MASTER LOCKNUT AND THE MASTER CYLINDER PIN IS 1/16" TO 1/8".

ADJUSTMENT OF ROD L.
 (1) ADJUST ROD L SO THAT THE CLEARANCE BETWEEN THE MASTER LOCKNUT AND THE MASTER CYLINDER PIN IS 1/16" TO 1/8".

ADJUSTMENT OF ROD M.
 (1) ADJUST ROD M SO THAT THE CLEARANCE BETWEEN THE MASTER LOCKNUT AND THE MASTER CYLINDER PIN IS 1/16" TO 1/8".

ADJUSTMENT OF ROD N.
 (1) ADJUST ROD N SO THAT THE CLEARANCE BETWEEN THE MASTER LOCKNUT AND THE MASTER CYLINDER PIN IS 1/16" TO 1/8".

ADJUSTMENT OF ROD O.
 (1) ADJUST ROD O SO THAT THE CLEARANCE BETWEEN THE MASTER LOCKNUT AND THE MASTER CYLINDER PIN IS 1/16" TO 1/8".

ADJUSTMENT OF ROD P.
 (1) ADJUST ROD P SO THAT THE CLEARANCE BETWEEN THE MASTER LOCKNUT AND THE MASTER CYLINDER PIN IS 1/16" TO 1/8".

ADJUSTMENT OF ROD Q.
 (1) ADJUST ROD Q SO THAT THE CLEARANCE BETWEEN THE MASTER LOCKNUT AND THE MASTER CYLINDER PIN IS 1/16" TO 1/8".

ADJUSTMENT OF ROD R.
 (1) ADJUST ROD R SO THAT THE CLEARANCE BETWEEN THE MASTER LOCKNUT AND THE MASTER CYLINDER PIN IS 1/16" TO 1/8".

ADJUSTMENT OF ROD S.
 (1) ADJUST ROD S SO THAT THE CLEARANCE BETWEEN THE MASTER LOCKNUT AND THE MASTER CYLINDER PIN IS 1/16" TO 1/8".

ADJUSTMENT OF ROD T.
 (1) ADJUST ROD T SO THAT THE CLEARANCE BETWEEN THE MASTER LOCKNUT AND THE MASTER CYLINDER PIN IS 1/16" TO 1/8".

ADJUSTMENT OF ROD U.
 (1) ADJUST ROD U SO THAT THE CLEARANCE BETWEEN THE MASTER LOCKNUT AND THE MASTER CYLINDER PIN IS 1/16" TO 1/8".

ADJUSTMENT OF ROD V.
 (1) ADJUST ROD V SO THAT THE CLEARANCE BETWEEN THE MASTER LOCKNUT AND THE MASTER CYLINDER PIN IS 1/16" TO 1/8".

ADJUSTMENT OF ROD W.
 (1) ADJUST ROD W SO THAT THE CLEARANCE BETWEEN THE MASTER LOCKNUT AND THE MASTER CYLINDER PIN IS 1/16" TO 1/8".

ADJUSTMENT OF ROD X.
 (1) ADJUST ROD X SO THAT THE CLEARANCE BETWEEN THE MASTER LOCKNUT AND THE MASTER CYLINDER PIN IS 1/16" TO 1/8".

ADJUSTMENT OF ROD Y.
 (1) ADJUST ROD Y SO THAT THE CLEARANCE BETWEEN THE MASTER LOCKNUT AND THE MASTER CYLINDER PIN IS 1/16" TO 1/8".

ADJUSTMENT OF ROD Z.
 (1) ADJUST ROD Z SO THAT THE CLEARANCE BETWEEN THE MASTER LOCKNUT AND THE MASTER CYLINDER PIN IS 1/16" TO 1/8".

ADJUSTMENT OF ROD A.
 (1) ADJUST ROD A SO THAT THE CLEARANCE BETWEEN THE MASTER LOCKNUT AND THE MASTER CYLINDER PIN IS 1/16" TO 1/8".

ADJUSTMENT OF ROD B.
 (1) ADJUST ROD B SO THAT THE CLEARANCE BETWEEN THE MASTER LOCKNUT AND THE MASTER CYLINDER PIN IS 1/16" TO 1/8".

FIG. 20.

METHOD OF ADJUSTMENT OF BRAKE LINKAGES.

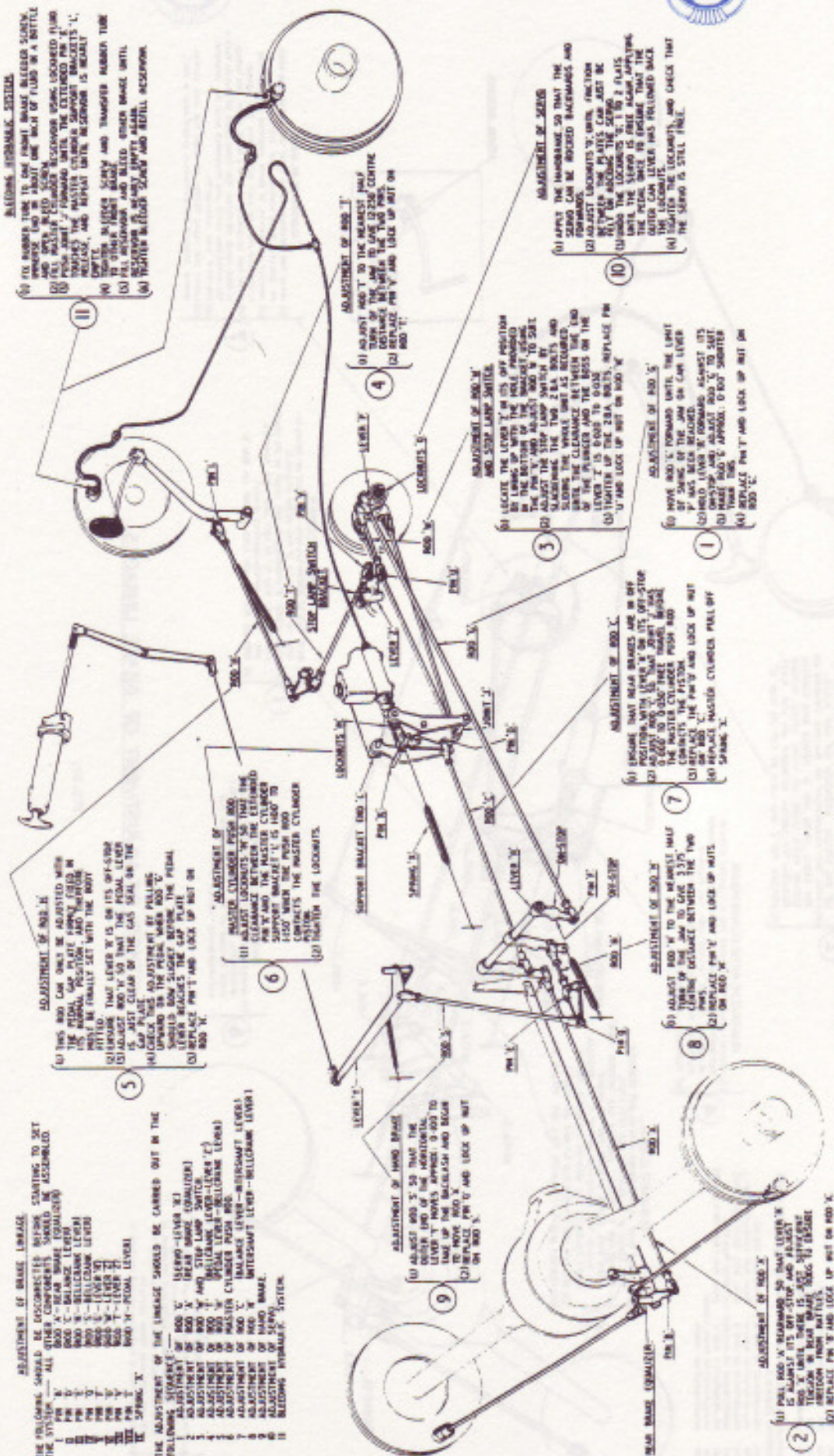

METHOD OF BRAKE LINKAGE ADJUSTMENT—LEFT HAND CARS

FIG 20A

Section J
Sub-Section BJ.5.

ADJUSTMENTS OF BRAKE LINKAGE

THE FOLLOWING SHOULD BE DISCONNECTED BEFORE STARTING TO SET THE SYSTEM—ALL OTHER COMPONENTS SHOULD BE ASSEMBLED.

- 1. PIN X
- 2. PIN Y
- 3. PIN Z
- 4. PIN W
- 5. PIN V
- 6. PIN U
- 7. PIN T
- 8. PIN S
- 9. PIN R
- 10. PIN Q
- 11. PIN P
- 12. PIN O
- 13. PIN N
- 14. PIN M
- 15. PIN L
- 16. PIN K
- 17. PIN J
- 18. PIN I
- 19. PIN H
- 20. PIN G
- 21. PIN F
- 22. PIN E
- 23. PIN D
- 24. PIN C
- 25. PIN B
- 26. PIN A

THE ADJUSTMENT OF THE LINKAGE SHOULD BE CARRIED OUT IN THE FOLLOWING ORDER:

1. ADJUSTMENT OF ROD X
2. ADJUSTMENT OF ROD Y
3. ADJUSTMENT OF ROD Z
4. ADJUSTMENT OF ROD W
5. ADJUSTMENT OF ROD V
6. ADJUSTMENT OF ROD U
7. ADJUSTMENT OF ROD T
8. ADJUSTMENT OF ROD S
9. ADJUSTMENT OF ROD R
10. ADJUSTMENT OF ROD Q
11. ADJUSTMENT OF ROD P
12. ADJUSTMENT OF ROD O
13. ADJUSTMENT OF ROD N
14. ADJUSTMENT OF ROD M
15. ADJUSTMENT OF ROD L
16. ADJUSTMENT OF ROD K
17. ADJUSTMENT OF ROD J
18. ADJUSTMENT OF ROD I
19. ADJUSTMENT OF ROD H
20. ADJUSTMENT OF ROD G
21. ADJUSTMENT OF ROD F
22. ADJUSTMENT OF ROD E
23. ADJUSTMENT OF ROD D
24. ADJUSTMENT OF ROD C
25. ADJUSTMENT OF ROD B
26. ADJUSTMENT OF ROD A

BLEEDING STOPPAGE SYSTEM

- (1) TO REMOVE THE AIR FROM THE BLEEDER SCREW, REMOVE THE AIR FROM THE MAIN OF FLUID IN A BOTTLE.
- (2) TO REMOVE THE AIR FROM THE BLEEDER SCREW, REMOVE THE AIR FROM THE MAIN OF FLUID IN A BOTTLE.
- (3) TO REMOVE THE AIR FROM THE BLEEDER SCREW, REMOVE THE AIR FROM THE MAIN OF FLUID IN A BOTTLE.
- (4) TO REMOVE THE AIR FROM THE BLEEDER SCREW, REMOVE THE AIR FROM THE MAIN OF FLUID IN A BOTTLE.
- (5) TO REMOVE THE AIR FROM THE BLEEDER SCREW, REMOVE THE AIR FROM THE MAIN OF FLUID IN A BOTTLE.
- (6) TO REMOVE THE AIR FROM THE BLEEDER SCREW, REMOVE THE AIR FROM THE MAIN OF FLUID IN A BOTTLE.
- (7) TO REMOVE THE AIR FROM THE BLEEDER SCREW, REMOVE THE AIR FROM THE MAIN OF FLUID IN A BOTTLE.
- (8) TO REMOVE THE AIR FROM THE BLEEDER SCREW, REMOVE THE AIR FROM THE MAIN OF FLUID IN A BOTTLE.
- (9) TO REMOVE THE AIR FROM THE BLEEDER SCREW, REMOVE THE AIR FROM THE MAIN OF FLUID IN A BOTTLE.
- (10) TO REMOVE THE AIR FROM THE BLEEDER SCREW, REMOVE THE AIR FROM THE MAIN OF FLUID IN A BOTTLE.
- (11) TO REMOVE THE AIR FROM THE BLEEDER SCREW, REMOVE THE AIR FROM THE MAIN OF FLUID IN A BOTTLE.

ADJUSTMENT OF ROD J

- (1) ADJUST ROD J TO THE NEAREST HALF TURN OF THE JAM TO GIVE 22MM CENTRE DISTANCE BETWEEN THE TWO PINS.
- (2) REPLACE PIN Y AND LOCK UP SET ON ROD Y.

ADJUSTMENT OF ROD K

- (1) LOCATE THE LEVER T IN ITS OFF POSITION.
- (2) ADJUST THE LEVER T TO THE NEAREST HALF TURN OF THE JAM TO GIVE 22MM CENTRE DISTANCE BETWEEN THE TWO PINS.
- (3) ADJUST THE STOP LAMP SWITCH BY SLACKENING THE TWO 2BA BOLTS AND SLEWING THE WHEEL SHOCK ASSEMBLY LEVER UP TO THE POSITION OF THE 2BA BOLTS ON THE LEVER T IS GOOD TO 0.025.
- (4) TIGHTEN UP THE 2BA BOLTS, REPLACE PIN U AND LOCK UP SET ON ROD W.

ADJUSTMENT OF ROD L

- (1) APPLY THE HANDBRAKE SO THAT THE SERVO CAN BE ROUGHED BACKWARDS AND FORWARDS.
- (2) ADJUST LOCATOR V, WITH FINGER TIPS, TO THE POSITION OF THE SERVO.
- (3) HOLD THE LOCATOR V IN 2 PLAYS UNTIL THE LEVER IS FREE AGAIN, APPLYING THE PEDAL ONCE TO ENSURE THAT THE OUTER CAN LEVER HAS FOLLOWED BACK.
- (4) TIGHTEN THE LOCATOR V, AND CHECK THAT THE SERVO IS STILL FREE.

ADJUSTMENT OF ROD M

- (1) MOVE ROD M FORWARD UNTIL THE LIMIT OF TRAVEL OF THE JAM ON CAN LEVER P HAS BEEN REACHED.
- (2) HOLD LEVER X FORWARD AGAINST ITS STOP AND TIGHTEN UP SPRING X.
- (3) HOLD ROD M APPROX. 0.005 SHORTER THAN 206.
- (4) REPLACE PIN Y AND LOCK UP SET ON ROD V.

ADJUSTMENT OF ROD N

- (1) ENSURE THAT REAR BRAKES ARE IN OFF POSITION WITH LEVER X ON ITS OFF-STOP.
- (2) ADJUST THE MASTER CYLINDER PUSH ROD TO THE POSITION OF THE MASTER CYLINDER PUSH ROD CONTACTS THE PISTON.
- (3) REPLACE THE PIN Y AND LOCK UP SET ON ROD V.
- (4) REPLACE MASTER CYLINDER PULL OFF SPRING X.

ADJUSTMENT OF ROD O

- (1) ADJUST ROD O TO THE NEAREST HALF TURN OF THE JAM TO GIVE 22MM CENTRE DISTANCE BETWEEN THE TWO PINS.
- (2) REPLACE PIN Y AND LOCK UP SET ON ROD V.

ADJUSTMENT OF ROD P

- (1) FULL ROD X FORWARD SO THAT LEVER X IS AGAINST ITS OFF-STOP AND ADJUST ROD X UNTIL THERE IS 0.025 BETWEEN THE MASTER CYLINDER PULL OFF AND THE PISTON.
- (2) REPLACE PIN Y AND LOCK UP SET ON ROD X.



THE HYDRAULIC MASTER CYLINDER AND RESERVOIR.

No attention is likely to be required by the hydraulic master cylinder other than topping up of the reservoir every 10,000 miles with the Recommended Brake Fluid. Access to the filler plug (14, Fig.21) is obtained by removal of a small panel in the floorboards underneath the driver's seat.

In the event of it being necessary to dismantle the master cylinder, for instance, after use of an incorrect brake fluid, which would damage the rubber components, proceed as follows:-

TO REMOVE MASTER CYLINDER FROM CHASSIS.

Provided that a pit or rem is available, the master cylinder is more easily removed from underneath, complete with its mounting bracket and the levers which are attached to it.

- (i) Remove pin 'D' (Fig.20, Sub-Section BJ.3) thus disconnecting rod 'C'.
- (ii) Remove the nut, bolt and distance piece from joint 'J', thus disconnecting the two servo pull rods.
- (iii) Unhook spring 'X'.
- (iv) Disconnect the hydraulic pipe line from the front of the master cylinder. (Hold the union (17 Fig.21) with one spanner while undoing the sleeve nut. This will prevent the pipe being twisted.)

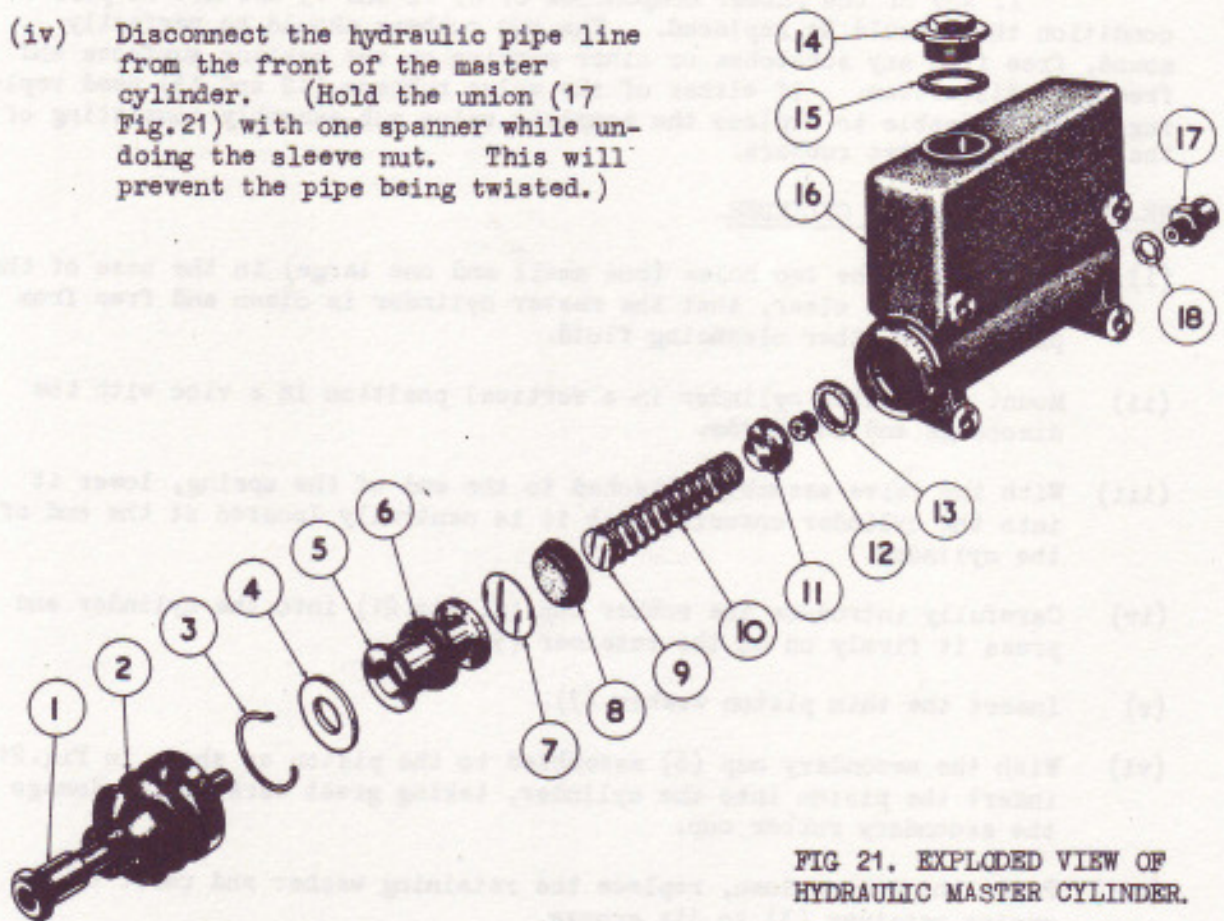

FIG 21. EXPLODED VIEW OF HYDRAULIC MASTER CYLINDER.



- (v) Disconnect the master cylinder mounting bracket from the frame cruciform member by removing the five retaining bolts. The complete unit can now be removed from the chassis.
- (vi) Remove the master cylinder unit from its mounting bracket by removing the four retaining bolts.

DISMANTLING THE MASTER CYLINDER.

- (i) The push rod (1, Fig.21) has already been removed as it was attached to the levers when the master cylinder was removed from the bracket.
- (ii) Remove the rubber boot.
- (iii) Unscrew the filler plug (14) and drain out the fluid.
- (iv) Extract the piston stop retaining ring (3) from its groove and then remove the piston stop washer (4). This will enable the remaining components to be removed from the cylinder for inspection.

SERVICE OPERATIONS.

If any of the rubber components 6, 8, 12 and 13 are not in perfect condition they should be replaced. The cup rubbers should be perfectly sound, free from any scratches or other marking on the sealing surfaces and free from distortion. If either of the valve rubbers (12 and 13) need replacing it is advisable to replace the complete valve sub-assembly consisting of the body and the two rubbers.

RE-ASSEMBLING MASTER CYLINDER.

- (i) Ensure that the two holes (one small and one large) in the base of the reservoir are clear, that the master cylinder is clean and free from paraffin or other cleansing fluid.
- (ii) Mount the master cylinder in a vertical position in a vice with the discharge end downwards.
- (iii) With the valve assembly attached to the end of the spring, lower it into the cylinder ensuring that it is centrally located at the end of the cylinder.
- (iv) Carefully introduce the rubber cup (8, Fig.21) into the cylinder and press it firmly on to the retainer (9).
- (v) Insert the thin piston washer (7).
- (vi) With the secondary cup (6) assembled to the piston as shown in Fig.21 insert the piston into the cylinder, taking great care not to damage the secondary rubber cup.
- (vii) Press the piston down, replace the retaining washer and refit the spring retainer (3) to its groove.
- (viii) Refit the rubber gaiter (2).



RE-FITTING MASTER CYLINDER TO CAR.

- (i) First it will be necessary to re-assemble the master cylinder to the mounting bracket. The push rod (1) which is still attached to the levers, can be pushed through the rubber gaiter and into the hollow in the master piston. Replace the four through bolts which retain the master cylinder (fit the bolts with the bolt heads away from the frame cruciform). Fit the spring washers and nuts and tighten up.
- (ii) The remainder of the instructions for replacing the assembly on the chassis are approximately the reversal of the instructions for removal, bearing in mind the following points:-
- (iii) Adjust the brake linkages as described on Fig.20, Sub-Section BJ.3.
- (iv) Re-fill the master cylinder reservoir with the Recommended Brake Fluid and then remove all air from the system by bleeding the brakes as described in the appropriate paragraph of Sub-Section BJ.2.



THE SERVO MOTOR.

GENERAL.

The servo motor is of the dry disc-brake type, and is driven from the gearbox output at approximately one tenth of the propeller shaft speed.

In the event of low or inconsistent servo output which would be indicated by heavy or non-progressive brake pedal action together with insufficient front braking, the servo should be dismantled and examined.

The following are possible causes of trouble:-

- (a) Oil or other foreign matter on the friction faces.
- (b) Dirt or lack of lubricant on the working parts.
- (c) Grooving of the servo shaft or outer race of the three row ball bearing.
- (d) Indentation of the cam faces by the balls.
- (e) Excessive clearance due to wear of the friction faces or incorrect adjustment.

The following instructions are given for dismantling the servo for inspection of these points, and it should be noted that if oil has found its way on to the friction surfaces it will be essential to ascertain the source of leak and effect a cure.

Should the leak be traced to the oil seal as fitted to the servo drive shaft (gearbox) being faulty or worn out, then refer to the appropriate paragraph: "To replace the oil seal as fitted to the Servo Drive Shaft".

TO REMOVE THE SERVO FROM THE CHASSIS.

- (i) Remove right-hand engine undershield, below the servo.
- (ii) Check for tightness locknut (38, Fig.22). Remove pin from jaw (39), and without disturbing position of jaw, screw out pull rod 'H' from jaw (37).
- (iii) Check for tightness locknut (33). Remove pin from jaw (52), and without disturbing position of jaw, screw out pull rod "G" from jaw (36).
- (iv) Remove bolt (48) from joint 'J' (see "Exploded view of joint 'J' on Fig.22), in order to release the rear end of drag links (44) and (45). This will allow servo to be rotated to the most advantageous position for uncoupling the front end of the drag links from the two inner servo levers, as follows:-

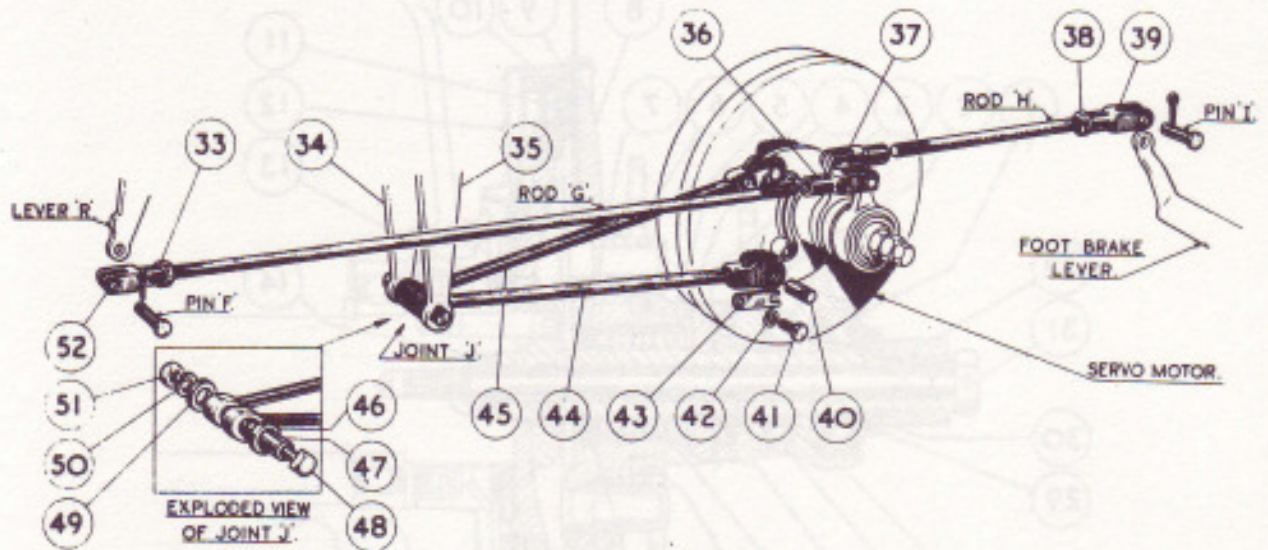

FIG. 22. SERVO CONNECTIONS.

- (v) Remove setscrews and spring washers (41 and 42), locking plates (43) and pins (40) from the front end of drag links.
- (vi) Remove servo retaining setscrew (31, Figs. 24 and 25) then, carefully pull the servo off the three driving pins (70, Fig. 27), taking care not to damage phosphor-bronze spring plate (12), against the chassis cross member.

NOTE: There is only about half an inch clearance at this point.

- (vii) Next, turn the servo inwards, i.e. draw the adjusting and locking nuts (30 and 32) (outer end of servo), towards the front of the car until they come on the inside of the cruciform member, and it will then be found that if the servo is drawn forwards at this angle it should just clear the frame.

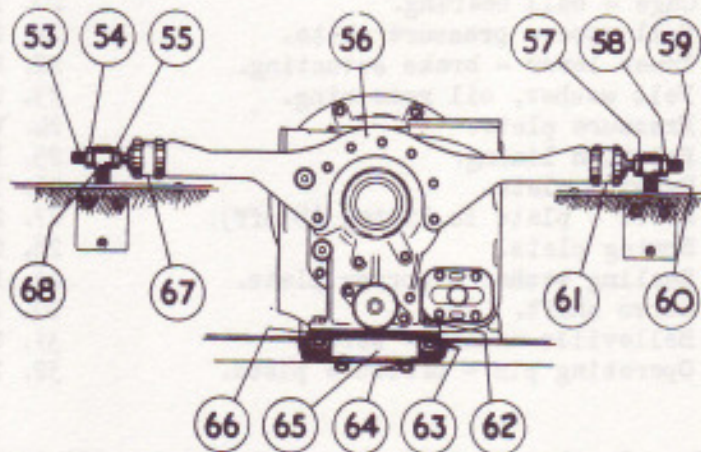

FIG. 23. ENGINE AND GEARBOX REAR MOUNTING.

- (viii) Remove Perodo sealing washer (13) from the gearbox.

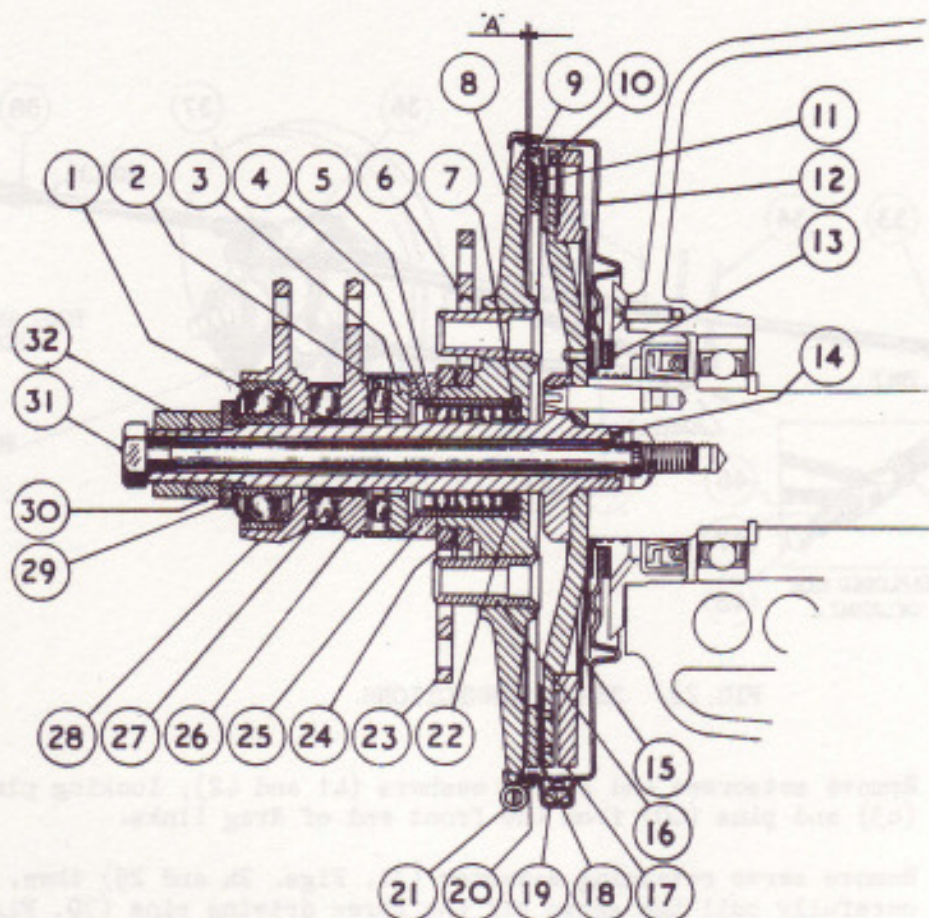

FIG. 24. SECTION THROUGH SERVO.

- | | |
|---|-------------------------------------|
| 1. Ball Bearing - outer lever. | 17. Inertia ring - servo. |
| 2. Cage - thrust bearing - cam levers) | 18. Spring Plate (9 off). |
| 3. Thrust race - cam levers) Assy: | 19. Water drain - servo (assy:). |
| 4. Cage - ball bearing. | 20. Protector - servo. |
| 5. Ball race - pressure plate. | 21. Spring - protector. |
| 6. Inner lever - brake actusting. | 22. Washer - felt retaining. |
| 7. Felt washer, oil retaining. | 23. Outer lever - brake actusting. |
| 8. Pressure plate. | 24. Washer - brake actusting lever. |
| 9. Friction lining. | 25. Dust cover - thrust bearing. |
| 10. Driving plate. | 26. Inner lever - servo operating. |
| 11. Rivet - plate to lining (9 off). | 27. Ball .3125" dia. (3 off). |
| 12. Spring plate. | 28. Outer lever - servo actusting. |
| 13. Sealing washer - spring plate. | 29. Plain washer - servo shaft. |
| 14. Servo shaft. | 30. Adjusting nut - servo. |
| 15. Belleville washer - servo. | 31. Setscrew - servo retaining. |
| 16. Operating pin - pressure plate. | 32. Locking nut - servo adjusting. |

NOTE: In the event of there not being sufficient clearance to withdraw the servo, the rear end of the gearbox will have to be moved sideways for approximately half an inch towards the left-hand side of the chassis. With a little ingenuity the following operations and the re-assembling, can be performed without removal of the floorboards.

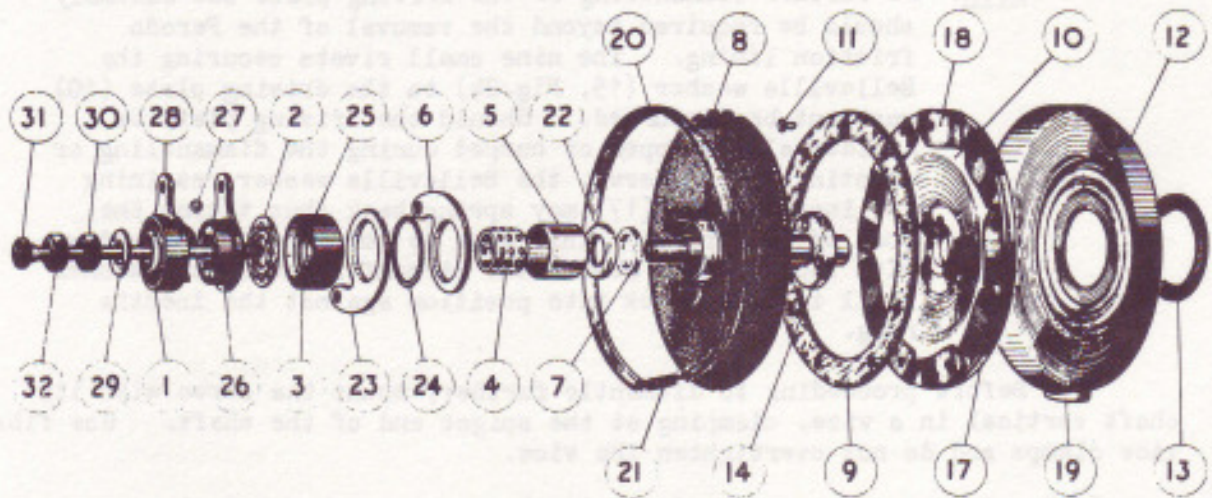

FIG. 25. "EXPLODED" VIEW OF SERVO.

Proceed as follows:-

- (a) Without disturbing the position of the outer nut (54, Fig.23), so as not to upset the original lateral adjustment of the left-hand side adjusting screw (53), slacken back the inner nut (55) as far as it will go, at same time, holding the outer cup (i.e. the one attached to the adjusting screw) by hand to prevent it turning, move the screw outwards and then withdraw the torque re-action rubber (67).
- The nuts (57 and 58) as fitted to the adjusting screw (59) on the right-hand side, should not be disturbed.
- (b) Remove two nuts and flat spring washers (63), and then remove the bolts (62), as fitted to the bottom and outermost holes in the gearbox rear end cover and support.
- (c) With the gear change lever in the neutral position, push or carefully lever the rear end of gearbox about half an inch towards the left-hand side of the chassis. This may dislodge the right-hand torque rubber (61) from its retaining cups.
- (d) Remove servo and Ferodo sealing washer (13).

TO DISMANTLE THE SERVO.

- (i) Pull the protector (20, Fig.25) off the servo, starting at the spring (21). This will allow driving plate sub-assembly (9, 10, 15 and 17) and the spring plate (12) to be separated from the rest of the servo.



NOTE: No further dismantling of the driving plate sub-assembly should be required beyond the removal of the Ferodo friction lining. The nine small rivets securing the Belleville washer (15, Fig. 24) to the driving plate (10) must not be disturbed. Should the driving plate be accidentally dropped or bumped during the dismantling or erecting of the servo, the Belleville washer retaining the inertia ring (17) may spring back thus taking the load off the ring. This must be corrected by pressing with four fingers around the circumference of the washer until it snaps back into position against the inertia ring.

Before proceeding to dismantle further, mount the servo with its shaft vertical in a vice, clamping at the spigot end of the shaft. Use fibre vice clamps and do not overtighten the vice.

- (ii) Remove the two nuts (32 and 30) and plain washer (29).
- (iii) Remove outer lever (28) complete with the ball bearing (1) taking care not to lose the three .3125" dia. balls (27).
- (iv) Remove inner lever (26), ball cage (2), dust cover and thrust bearing sub-assembly (25 and 3).
- (v) Remove lever (23), washer (24) and lever (6).
- (vi) Remove pressure plate (8) from the servo shaft, and then remove the ball cage (4) by inverting the pressure plate which will allow it to fall out. Remove the shaft from the vice.
- (vii) If the outer ball race (5) is worn, it should be replaced. To remove, apply a screwdriver to the felt retaining washer (22) and lightly tap it out. If the retaining washer is damaged during this operation, replace together with the felt washer (7).

TO RELINE THE SERVO.

It should seldom, if ever, be necessary to change the servo friction lining (Ferodo) due to wear; it would be necessary, however, if the lining had become contaminated with oil or other foreign matter. In this case the following procedure should be adopted:-

Before the rivets securing the friction lining to the spring plates (18) can be removed, it will be necessary to rotate the spring damped inertia ring (17), which forms part of the driving plate sub-assembly (10), until the access holes in it line up with the rivets securing the friction lining. A certain amount of effort will be required to rotate the inertia ring owing to the pressure exerted on it by the Belleville washer. Having uncovered three rivets as explained above, drill into the heads of the rivets thus exposed to a depth of approximately 1/16" using a .156" (5/32nd) dia. drill. This will allow the rivet to be easily removed. Care must be taken not to drill too deeply and so damage the spring plates. Repeat the above operations on the remainder of the rivets. Place the driving plate with the friction lining facing downwards on to a suitable flat surface and remove the rivets with a 1/8" dia. pin punch.



The Ferodo material used is of a brittle nature and must accordingly be handled and riveted with due care.

The driving face of the lining must be kept clean and free from all traces of oil, grease or finger marks.

Prior to riveting, check that both faces of the lining are flat and parallel.

When riveting up the new liner, the inertia ring will again have to be rotated to line up with the rivet access holes in the driving plate.

Place the Ferodo lining into position, insert two rivets as near diametrically opposite to one another as possible and lightly tap them in, ascertaining that the rivet head is well below the outer surface of the lining.

Fix a suitable "dolly" in a vice, the diameter of which should be the same size as the rivet head, i.e., .280" dia., place the rivet head on to the "dolly" and then, at this stage, lightly swage over the two rivets so as to keep the lining in position, using a taper ended punch as shown in Fig. 26.

Insert the remaining seven rivets, and lightly swage them over in a similar manner.

Finally, lightly swage over all rivets using a spigotted flat punch as shown in Fig. 26 and a light hammer. This operation must be done carefully to avoid splitting the lining.

Should there be any prominent irregularities of the surface of the friction lining after riveting, it may be cleaned up by rubbing it against a piece of coarse glass paper on a flat surface.

TO REPLACE THE OIL SEAL AS FITTED TO THE SERVO DRIVE SHAFT.

This will only be necessary if the existing oil seal is leaking.

In the event of a housing (73, Fig. 27) complete with an oil seal (71) not being available, then proceed as follows:

- (i) Remove the four countersunk screws (74) which secure the oil seal housing to the gearbox, then remove the housing.
- (ii) To remove oil seal from housing, place a suitable small curved drift on to the rear "flange" of the seal, and then, progressively and squarely tap it out taking care not to damage the Acme thread of the housing.

Once removed, the oil seal is scrap.

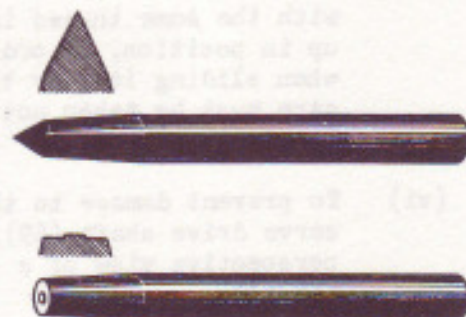

FIG. 26. THE TYPE OF PUNCHES USED WHEN RIVETING A NEW LINING IN POSITION.

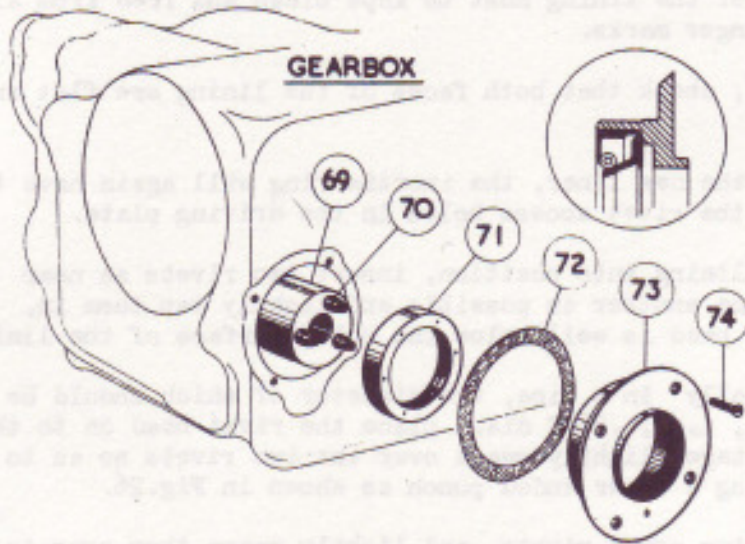

FIG. 27. OIL SEAL AND HOUSING "EXPLODED" FROM THE GEARBOX. INSET, THE OIL SEAL IS SHOWN CORRECTLY ASSEMBLED TO THE HOUSING.

(iii) To fit a new oil seal, place the seal squarely on to the housing with the tip of the seal pointing away from the Acme thread (the insert in Fig.27 shows the seal correctly fitted to the housing) and with the aid of a hand press, press the seal squarely into position.

(iv) Fit a new Vellumoid joint (72) on to the housing.

(v) Examine the outer end of the servo drive shaft (69, Fig.27) for signs of roughness or grooving due to possible contact

with the Acme thread in the housing (73). If so it should be cleaned up in position, in order that the new oil seal (71), will not be damaged when sliding it over this part of the shaft. When cleaning up the shaft, care must be taken not to touch the part of the shaft on which the seal bears.

(vi) To prevent damage to the tip of the oil seal while entering it on to the servo drive shaft (69), a tapered plug should be used. Fig.28 shows a perspective view of a suitable plug, and Fig.29 is a detailed drawing of the plug.

Place the tapered plug on to the three driving pins (70) of the servo drive shaft, then place the housing and seal over the tapered plug and carefully enter it on to the shaft tapping it carefully so as not to damage the seal.

Remove the tapered plug.

(vii) Turn the housing so that the small oil drain hole is at the bottom.

(viii) Secure the housing to the gearbox by means of the four countersunk screws (74).

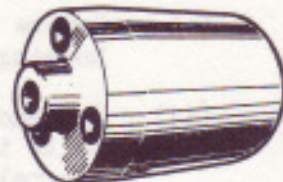

FIG. 28. TOOL USED TO PREVENT DAMAGE TO OIL SEAL WHEN ASSEMBLING IT TO THE SERVO SHAFT.

TO RE-ASSEMBLE THE SERVO.

The following operations should be carried out prior to assembling:



- (vi) Place inner lever sub-assembly (26) on to the bell cage (2), grease the recesses of the inner lever and replace the three .3125" dia. balls (27).
- (vii) Fit outer lever sub-assembly (1 and 28) on to the servo shaft, in correct relation with the inner lever (see Fig.22), followed by the plain washer (29) and the two nuts (30 and 32). Screw up together until approximately one thread of the servo shaft protrudes through the outer nut (32). Lock together temporarily in order to provide a means of rotating the shaft when assembling the servo motor to the gearbox. Remove servo shaft from the vice.
- (viii) Place driving plate sub-assembly (10) on to the servo shaft, then fit the spring plate (12) to the pressure plate (8), ensuring that the tab of the spring plate engages in the single lower slot in the pressure plate.
- (ix) Place protector (20) in position as follows, take care not to distort protector while fitting it:

With the spring anchored to both ends of the protector, place the protector over the spring plate and pressure plate in such a way that the spring is at the bottom and in line with the drain (19, Fig.24). "Smooth" and manoeuvre it into position by pressing with the thumb and finger round the circumference until the whole of it is in position.

TO REFIT THE SERVO TO THE GEARBOX.

- (i) Place the Ferodo sealing washer (13, Figs.24 and 25) in position on the gearbox, with the VG 100 face (black coloured) facing towards the servo.
- (ii) If due care is not taken while fitting the servo motor to the gearbox, it is possible that although the driving plate (10) has correctly engaged with the three driving pins (70, Fig.27) of the servo drive shaft (69), the flange of the servo shaft (14) may not have engaged with the driving pins. Therefore, the servo retaining setscrew (31, Fig.24) must not be fitted, until the servo shaft is fully engaged with the driving pins, or the flange might be clamped against the ends of the pins.

To ensure that this operation is correctly carried out proceed as follows:-

Place servo motor in position making sure that the three driving pins enter the holes in the driving plate, then rotate the servo shaft by means of the two nuts (30 and 32), applying pressure towards the gearbox, until the holes in the servo shaft flange engage with the driving pins. This will be apparent by the fact that the servo shaft cannot now be rotated, and by the fact that it has moved an appreciable distance further towards the gearbox.

Fit servo retaining setscrew (31), tighten up, then ascertain that the servo pressure plate can be freely rocked by hand, restrained only by the friction between the spring plate (12) and the Ferodo sealing washer (13).



REPOSITIONING THE REAR END OF THE GEARBOX & RE-ASSEMBLING
THE TORQUE RE-ACTION RUBBERS.

NOTE: Should it have been found necessary to move the rear end of the gearbox towards the left-hand side of the chassis for removal of the servo, proceed as follows:-

- (i) Make sure that the gear change lever is in the neutral position. While holding the right-hand torque rubber (61, Fig.23) in position between its retaining cups, the rear of the gearbox should be pushed or carefully levered back to its normal position in the chassis. As the placing in position of the right-hand torque rubber will have to be done by "feel", make sure that it has not been trapped on the edge of the cup holders; see Fig.23. With the torque rubber correctly positioned and with the packing pieces (66) in their correct position, refit the two bolts (62) and tighten up the nuts and flat spring washers (63). The function of these packing pieces, which may vary in number, is to ensure that the selector lever shaft (the horizontal shaft which enters the gearbox) shall be in line with the change gear lever shaft (to which it is coupled) and not sloping up or down.

- (ii) Place the left-hand torque rubber (67) in position in the inner cup, draw the outer cup (attached to the adjusting screw 53) on to the rubber and while holding the outer cup to prevent it turning, tighten up the inner nut (55) to lock. Providing the outer nut (54) has not been disturbed from its original position, the compression of the rubbers will not have been altered. However, should there be any doubt, then re-adjust as follows:-

Unscrew the outer nut (54) about six turns and slacken back the inner nut (55). Screw up inner nut finger tight so as to lightly clamp the rubbers between the holders, then with the aid of a spanner, tighten it a further two complete turns to give the correct compression of the rubbers. Tighten up the outer nut (54) to lock.

On no account may this adjustment be used to control the lateral positioning of the engine and gearbox unit, because the resulting unequal loads on the rubbers would reduce the effectiveness of the flexible mounting in suppressing noise and roughness, i.e. the torque re-action rubbers (61 and 67) are set at equal loads so as not to displace the gearbox laterally.

- (iii) Check that gear change lever slides freely from end to end of the gate.

REFITTING THE CONNECTIONS TO THE SERVO.

- (1) Rotate servo motor to the best position and then connect the front end of the two drag links (44 and 45, Fig.22) as follows:-

Place the front end of one of the two drag links on to the "upper" (inner) brake actuating lever (6, Fig.24) on the servo and insert



the pin (40, Fig.22). Fit the locking plate (43) into the recess in the pin, and secure with flat spring washer (42) and setscrew (41).

Repeat the same operations for the "lower" drag link connecting it to the "lower" (outer) brake actuating lever (23).

- (ii) Connect up the rear ends of the two drag links to the two operating levers (34 and 35, Fig.22, Joint "J"), the upper link being towards the centre of the chassis.

Place the bush (47) into the drag links.

Place one each of the two distance pieces (46 and 49) on to each end of the bush. Offer into position, and secure with the bolt (48), flat spring washer (50) and nut (51), making sure the nut is correctly tightened up.

- (iii) Screw the pull rod 'G' (Fig.22) tightly into the jaw (35) coupled to the outer lever (28, Fig.24) of the servo. After tightening, the alignment of the jaw (52) at the other end of the rod must be corrected by releasing the locknut (33) but keeping the jaw as near as possible to the original setting. Fit the pin 'F' to the jaw and lever 'R' (with the hole in the pin towards the centre of the chassis) and secure by fitting a new split pin of the correct size.

Finally, tighten locknut (33), taking care not to rotate the jaw.

- (iv) Screw the pull rod 'H' (servo to pedal) tightly into the jaw (37) coupled to the inner lever (26, Fig.24) of the servo, again adjusting the jaws as in the previous paragraph.

Fit the pin 'I' to the jaw (39) and the footbrake lever, secure by fitting a new split pin of the correct size. Finally, tighten locknut as before.

TO ADJUST THE SERVO.

- (i) Apply the handbrake, so that the servo can be rocked backwards and forwards.
- (ii) Adjust the nut (30) until friction can just be felt, while rocking the servo, between the pressure plate (8) and the Ferodo friction lining (9). Then, slacken it back $\frac{1}{2}$ turn, giving a clearance of approximately .018" at point 'A' (Fig.24), i.e. until the servo is free again. Apply the pedal once to ensure that the outer cam lever (28) has followed back the nut.
- (iii) Having obtained the correct setting, hold nut (30) with a spanner and tighten nut (32) with a second spanner to lock.
- (iv) Check the pedal travel required to open the cam levers (26 and 28) which should be between .250" and .500".
- (v) Finally inspect that no split pins, locking plates and flat spring washers have been omitted.